



scenik

invisibly superior

www.scenik.co.nz | 0800 235 2473

Kaweka Spigot PS1 - Balustrade

Structural Design Report, Job 20073
Scenik Fencing – Extra high wind zone, various locations.
December 2022

PRODUCER STATEMENT – PS1 DESIGN



association of
consulting and
engineering



Building Code Clause(s):	B1, F2, F4	Job number: 20073
ISSUED BY: <i>(Engineering Design Firm)</i>	ExtraMile Consulting Ltd	
TO: <i>(Client)</i>	Storetech Industries Limited	
TO BE SUPPLIED TO: <i>(Building Consent Authority)</i>	Relevant Territorial Authority	
IN RESPECT OF: <i>(Description of building work)</i>	Structural engineering design for proprietary balustrade system ('Kaweka' Fixing Spigot and stainless handrail)	
AT: <i>(Address)</i>	Various sites within occupancy and wind limits as stated on drawings	
LEGAL DESCRIPTION	Varies	

We have been engaged by Storetech Industries Limited to provide:

structural engineering design for proprietary balustrade system

in respect of the requirements of the Clause(s) of the Building Code specified above for all of the proposed building work.

The design carried out by ExtraMile Consulting Ltd has been prepared in accordance with:

- ✓ compliance documents issued by the Ministry of Business, Innovation & Employment (Verification method /acceptable solution): B1/VM1

The proposed building work covered by this producer statement is described in the drawings specified in the attached Schedule, together with the specification, and other documents set out in the attached Schedule.

On behalf of ExtraMile Consulting Ltd, and subject to:

- site verification of the following design assumptions:
 - Occupancy as stated on the drawings
 - Wind zones as stated on the drawings
- all proprietary products meeting their performance specification requirements;

I believe on reasonable grounds that:

- the balustrade, if constructed in accordance with the drawings, specifications, and other documents provided or listed in the attached Schedule, will comply with the relevant provisions of the Building Code specified above; and that
- the persons who have undertaken the design have the necessary competence to do so.

I recommend the Nil level of construction monitoring.

Job Number: 20073

Job Address: Various sites within occupancy and wind limits as stated on drawings, and wind limits as stated on drawings
Compilation Date and Time: 5 December 2022 at 9:53 AM

I, Pawel Michal Milewski, am:

- CPEng number 1021657
- and hold the following qualifications: MEng(Hons)

ExtraMile Consulting Ltd holds a current policy of Professional Indemnity Insurance no less than \$200,000.

ExtraMile Consulting Ltd is not a member of ACE New Zealand.

SIGNED BY: Pawel Michal Milewski

(Signature):



Date: 5/12/2022

ON BEHALF OF: ExtraMile Consulting Ltd

Note: This statement has been prepared solely for Hastings District Council and shall not be relied upon by any other person or entity. Any liability in relation to this statement accrues to ExtraMile Consulting Ltd only. As a condition of reliance on this statement, Hastings District Council accepts that the total maximum amount of liability of any kind arising from this statement and all other statements provided to Hastings District Council in relation to this building work, whether in tort or otherwise, is limited to the sum of \$200,000.

This form is to accompany **Form 2 of the Building (Forms) Regulations 2004** for the application of a Building Consent.

SCHEDULE TO PS1

Please include an itemised list of all referenced documents, drawings, or other supporting materials in relation to this producer statement below:

- [B2 Letter in Lieu - Design](#)
- [Engineering Drawing Set: 20073_Kaweka_Fixing_Spigot_Balustrade_R.2_Drgs KB01 to KB04](#)
- [F2 Letter of compliance for glass used in the Storetech balustrade system](#)
- [Handrail compliance to comply with F4 and NZS4223:2016](#)

Job Number: 20073

Job Address: Various sites within occupancy and wind limits as stated on drawings, and wind limits as stated on drawings
Compilation Date and Time: 5 December 2022 at 9:53 AM

PS1 - DESIGN – SEPTEMBER 2021



PAGE 3 OF 5

GUIDANCE ON USE OF PRODUCER STATEMENTS

Information on the use of Producer Statements and Construction Monitoring Guidelines can be found on either the [ACE New Zealand](#) or [Engineering New Zealand](#) websites.

Producer statements were first introduced with the Building Act 1991. The producer statements were developed by a combined task committee consisting of members of the New Zealand Institute of Architects (NZIA), Institution of Professional Engineers New Zealand (now Engineering New Zealand), Association of Consulting and Engineering New Zealand (ACE NZ) in consultation with the Building Officials Institute of New Zealand (BOINZ). The original suite of producer statements has been revised at the date of this form to ensure standard use within the industry.

The producer statement system is intended to provide Building Consent Authorities (BCAs) with part of the reasonable grounds necessary for the issue of a Building Consent or a Code Compliance Certificate, without necessarily having to duplicate review of design or construction monitoring undertaken by others.

PS1 DESIGN: Intended for use by a suitably qualified independent engineering design professional in circumstances where the BCA accepts a producer statement for establishing reasonable grounds to issue a Building Consent;

PS2 DESIGN REVIEW: Intended for use by a suitably qualified independent engineering design review professional where the BCA accepts an independent design professional's review as the basis for establishing reasonable grounds to issue a Building Consent;

PS3 CONSTRUCTION: Forms commonly used as a certificate of completion of building work are Schedule 6 of NZS 3910:2013 or Schedules E1/E2 of NZIA's SCC 20112

PS4 CONSTRUCTION REVIEW: Intended for use by a suitably qualified independent engineering construction monitoring professional who either undertakes or supervises construction monitoring of the building works where the BCA requests a producer statement prior to issuing a Code Compliance Certificate.

This must be accompanied by a statement of completion of building work (Schedule 6).

The following guidelines are provided by ACE New Zealand and Engineering New Zealand to interpret the Producer Statement.

Competence of Engineering Professional

This statement is made by an engineering firm that has undertaken a contract of services for the services named, and is signed by a person authorised by that firm to verify the processes within the firm and competence of its personnel.

The person signing the Producer Statement on behalf of the engineering firm will have a professional qualification and proven current competence through registration on a national competence-based register such as a Chartered Professional Engineer (CPEng).

Membership of a professional body, such as Engineering New Zealand provides additional assurance of the designer's standing within the profession. If the engineering firm is a member of ACE New Zealand, this provides additional assurance about the standing of the firm.

Persons or firms meeting these criteria satisfy the term "suitably qualified independent engineering professional".

Professional Indemnity Insurance

As part of membership requirements, ACE New Zealand requires all member firms to hold Professional Indemnity Insurance to a minimum level.

The PI Insurance minimum stated on the front of this form reflects standard practice for the relationship between the BCA and the engineering firm.

Professional Services during Construction Phase

There are several levels of service that an engineering firm may provide during the construction phase of a project (CM1-CM5 for engineers³). The BCA is encouraged to require that the service to be provided by the engineering firm is appropriate for the project concerned.

Requirement to provide Producer Statement PS4

BCAs should ensure that the applicant is aware of any requirement for producer statements for the construction phase of building work at the time the building consent is issued. No design professional should be expected to provide a producer statement unless such a requirement forms part of ExtraMile Consulting Ltd's engagement.

Refer Also:

- 1 Conditions of Contract for Building & Civil Engineering Construction NZS 3910: 2013
- 2 NZIA Standard Conditions of Contract SCC 2011
- 3 Guideline on the Briefing & Engagement for Consulting Engineering Services (ACE New Zealand/Engineering New Zealand 2004)
- 4 PN01 Guidelines on Producer Statements

www.acenz.org.nz

www.engineeringnz.org

LETTER IN LIEU – DESIGN

To the Building Official,

Structural engineering design for proprietary balustrade system ('Kaweka' Fixing Spigot) at Various sites within occupancy and wind limits as stated on drawings, and wind limits as stated on drawings

COMPLIANCE WITH BUILDING CODE CLAUSE B2 – DURABILITY

The purpose of this letter is to demonstrate how compliance with Clause B2 (Durability) of the Building Code will be achieved for the above project. We can confirm that for specifically designed structural elements that are included within our design documentation:

Material	Means of Compliance	Details
Stainless Steel	B2/AS1	brackets and all fixings to be stainless steel

Yours faithfully,



Pawel Michal Milewski

For and on behalf of

ExtraMile Consulting Ltd

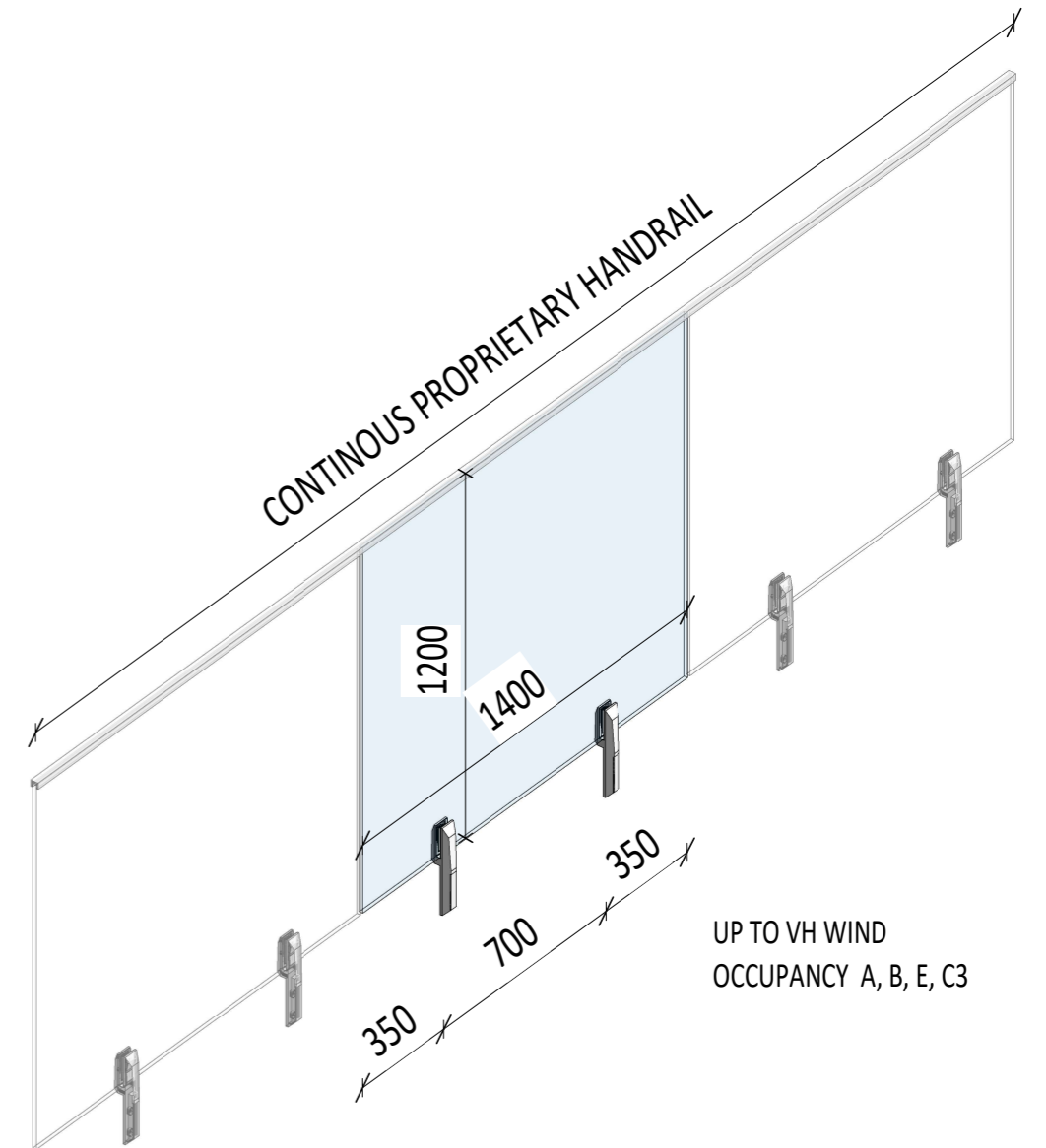
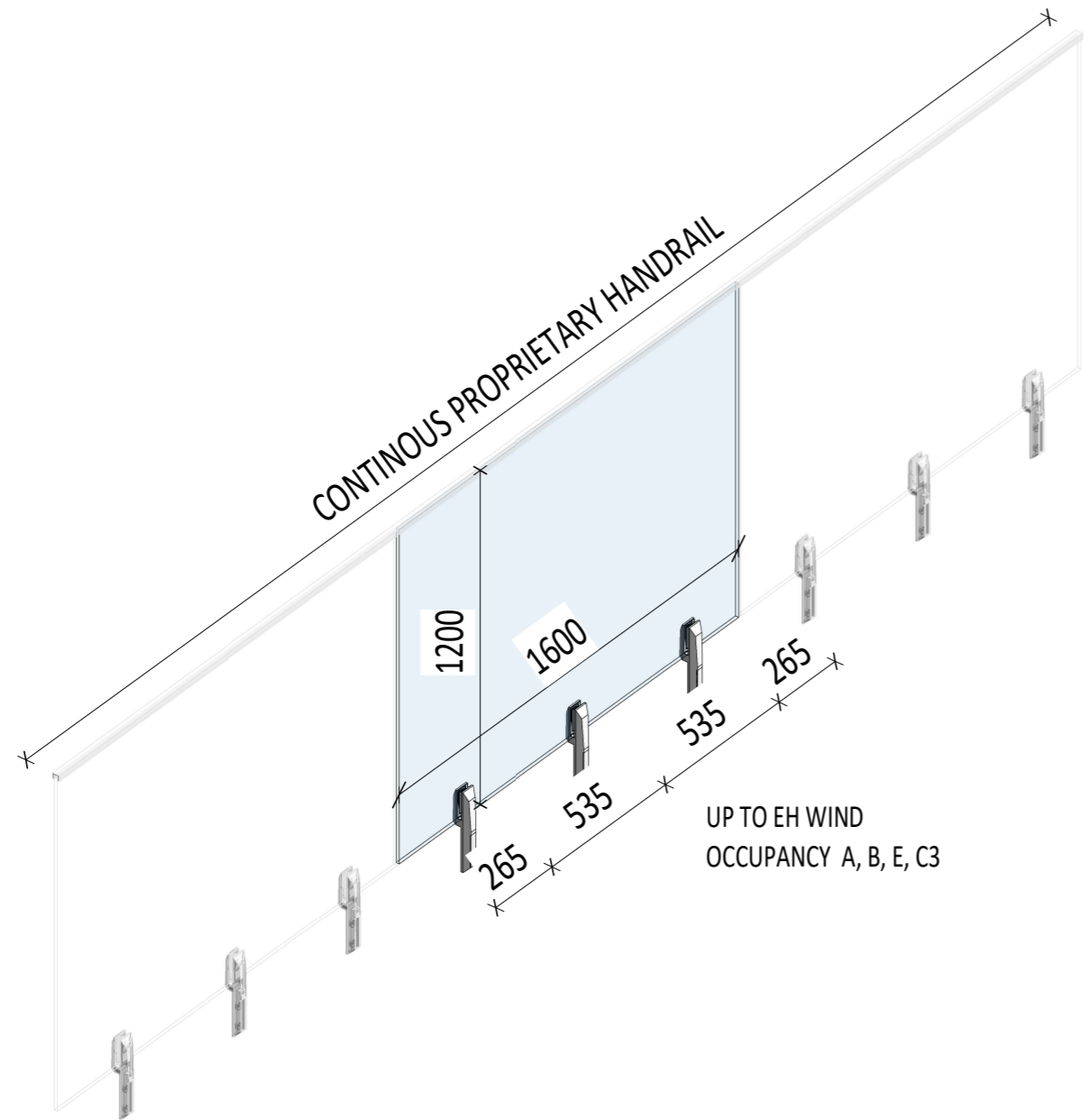

REF.	DESCRIPTION	DATE
R.0	INFORMATION	220719
R.1	CHEMICAL FIXING ADDED	220919
R.2	CONCRETE FIXING REVISED	221202
scale: @A3	drawn: AM	checked: PM
	status: P	project no: 20073
	drg no: KB01	rev: R.2

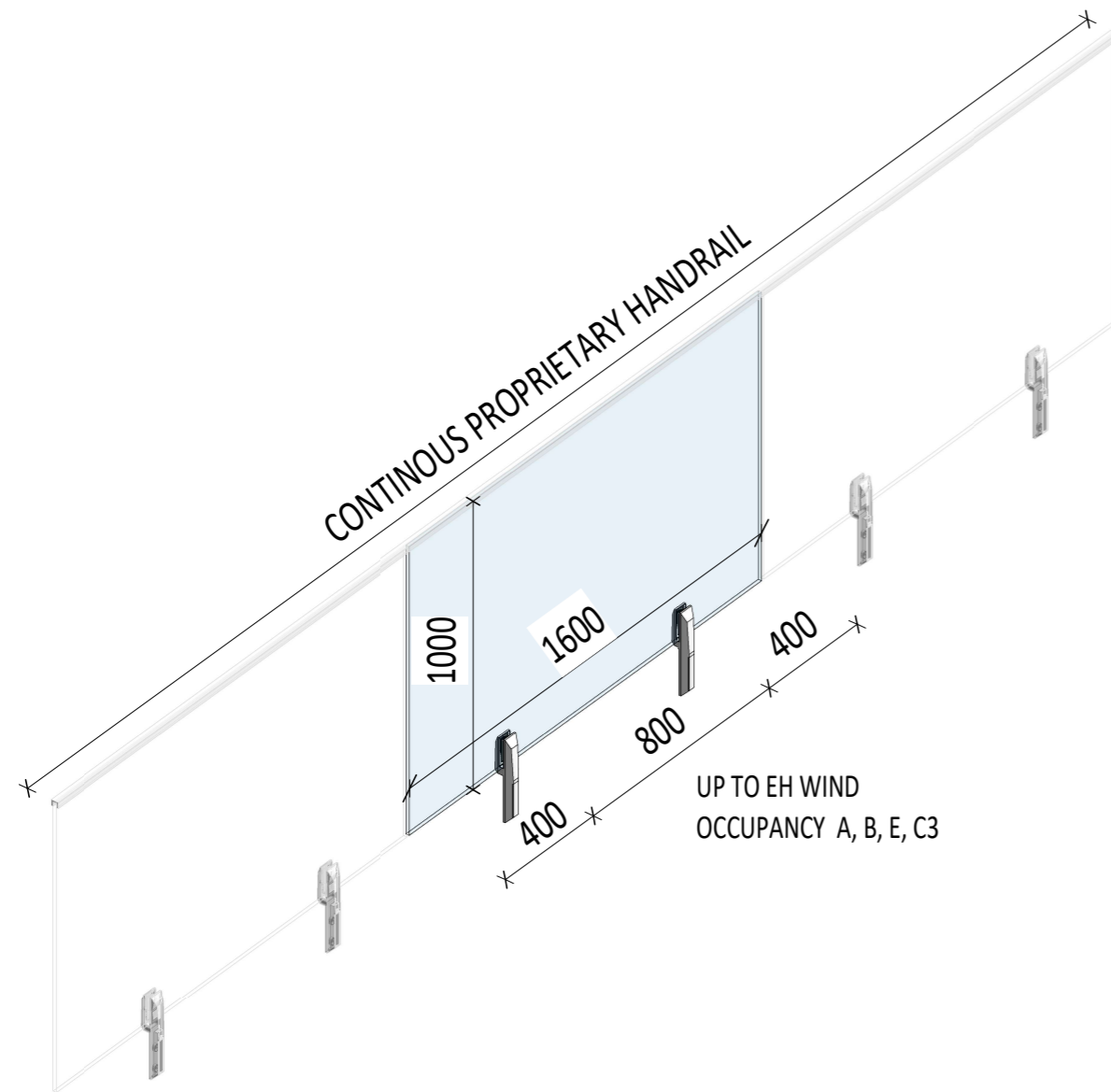

REF.	DESCRIPTION	DATE
R.0	INFORMATION	220719
R.1	CHEMICAL FIXING ADDED	220919
R.2	CONCRETE FIXING REVISED	221202
scale: @A3	drawn: AM	checked: PM
	status: P	project no: 20073
	drg no: KB02	rev: R.2

MIN. SG8 TIMBER BY DESIGNED BY OTHERS,
TO BE SUFFICIENTLY STRONG AND STIFF TO TRANSFER THE BALUSTRADE
LOADS

B - TIMBER DEPTH MIN. $A+70+A=170\text{mm}$
C - TIMBER WIDTH MIN. 90mm

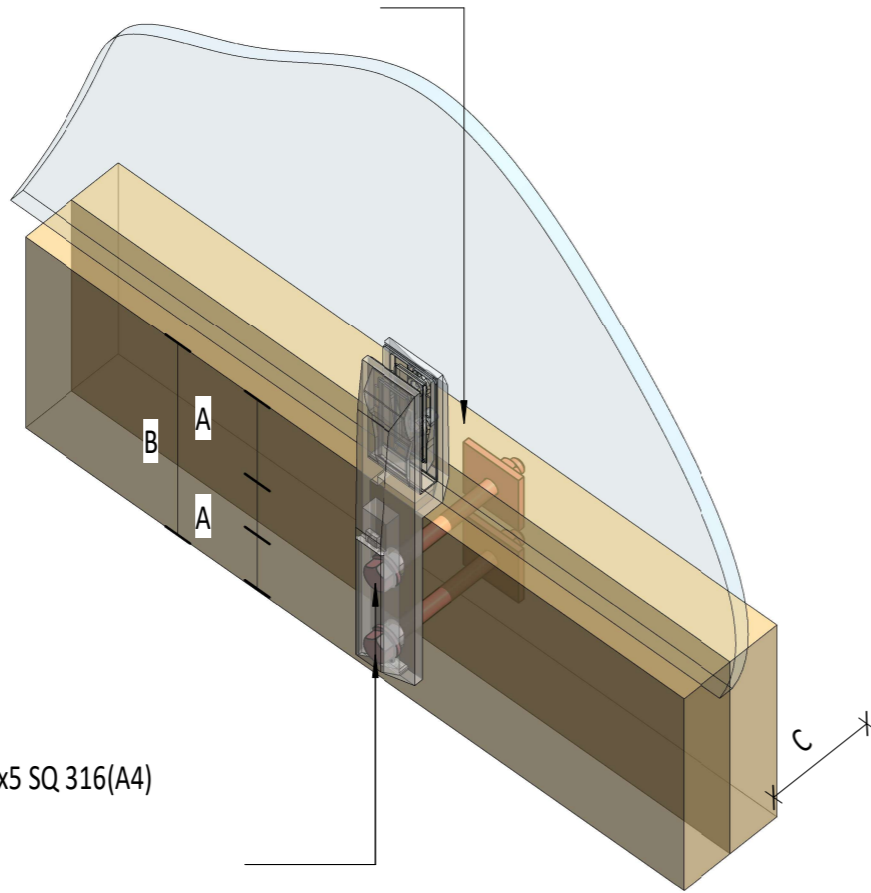

2/ M10 316(A4) HEX HEAD BOLTS WITH 50x5 SQ 316(A4)
WASHERS FROM TIMBER SIDE.
(WET TIMBER)

A - EDGE DISTANCE MIN. 50mm

OPTION 1

MIN. SG8 TIMBER BY DESIGNED BY OTHERS,
TO BE SUFFICIENTLY STRONG AND STIFF TO TRANSFER THE BALUSTRADE
LOADS

B - MIN. TIMBER DEPTH $A+70+A=170\text{mm}$
C - MIN. TIMBER WIDTH 135mm

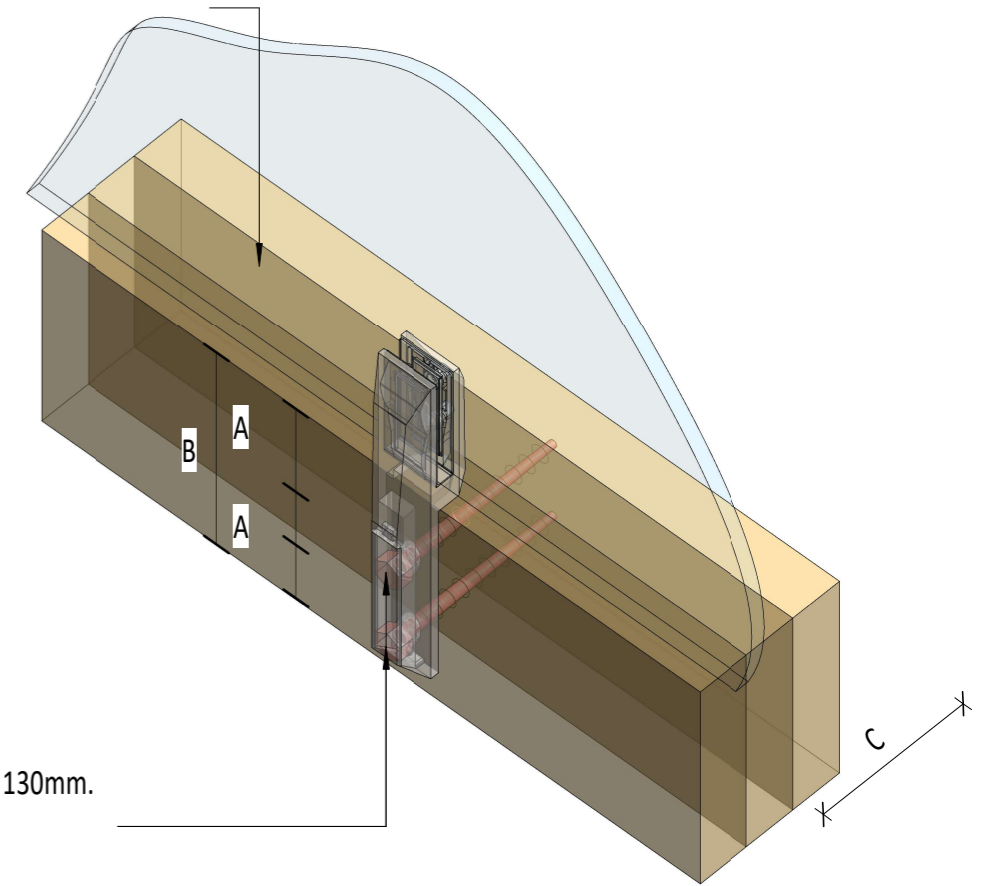

2/ M12 316(A4) HEX HEAD COACH SCREWS
LENGTH OF THREAD PENETRATION INTO TIMBER MIN. 130mm.
(DRY TIMBER)

A - MIN. EDGE DISTANCE MIN. 50mm

OPTION 2

CONNECTION TO TIMBER

REF.	DESCRIPTION	DATE
R.2	CONCRETE FIXING REVISED	221202
R.3	WURTH ANCHORS AND GLASS NOTE ADDED. CONC. EDGE DIST. CHANGED.	230922
R.4	M12 ANCHORS REPLACED WITH M10 WHERE RELEVANT	230929
scale: @A3	drawn: AM	checked: PM
	status: P	project no: 20073
	drg no: KB04	rev: R.4

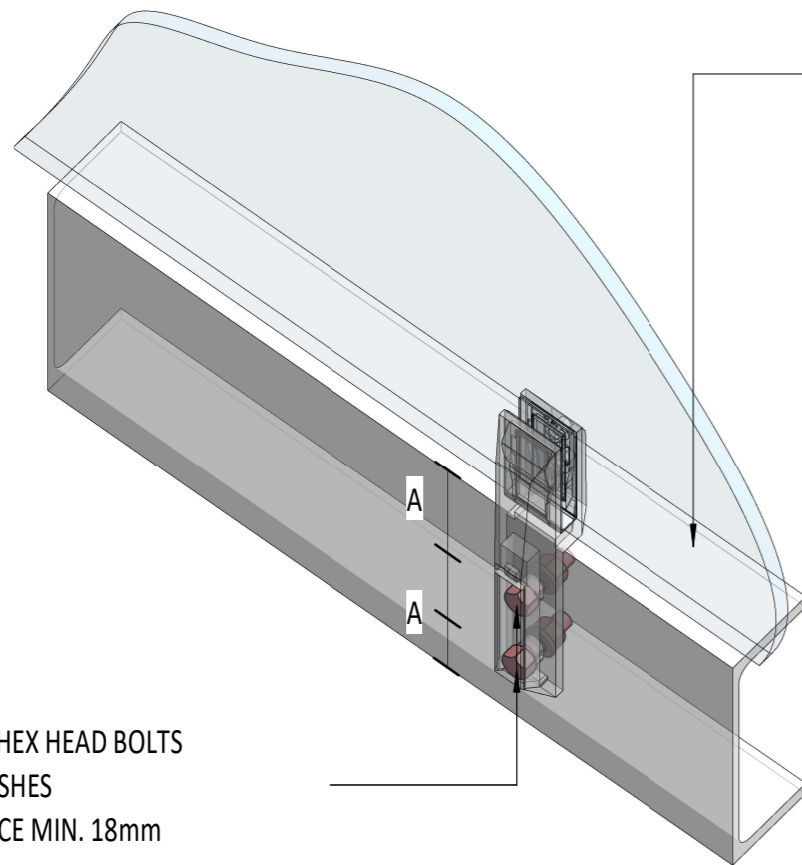

STRUCTURAL STEELWORK
DESIGNED BY OTHERS TO HAVE SUFFICIENT STRENGTH AND RIGIDITY TO SUPPORT THE BALUSTRADE

2/M10 316(A4) HEX HEAD BOLTS
WITH NYLON-BUSHES
A - EDGE DISTANCE MIN. 18mm

CONNECTION TO STRUCTURAL STEEL

MECHANICAL ANCHORS FOR 55mm EDGE DISTANCE:

2/W-FAZ PRO/S M10 x 110 (A4) STAINLESS STEEL BY WURTH,
MIN.75mm INTO CONCRETE

A - EDGE DISTANCE MIN. 55mm,
B - CORNER DISTANCE MIN. 265mm

MECHANICAL ANCHORS FOR 65mm EDGE DISTANCE:

2/W-BS 2-H SW M10 x 120 (A4) STAINLESS STEEL BY WURTH,
MIN.95mm INTO CONCRETE

CHEMICAL ANCHORS FOR 65mm EDGE DISTANCE:

WIT-UH 300 + 2/M10 THREADED RODS (MIN.155 LONG) 316/A4 STAINLESS STEEL BY WURTH
MIN.125mm INTO CONCRETE

A - EDGE DISTANCE MIN. 65mm,
B - CORNER DISTANCE MIN. 265mm

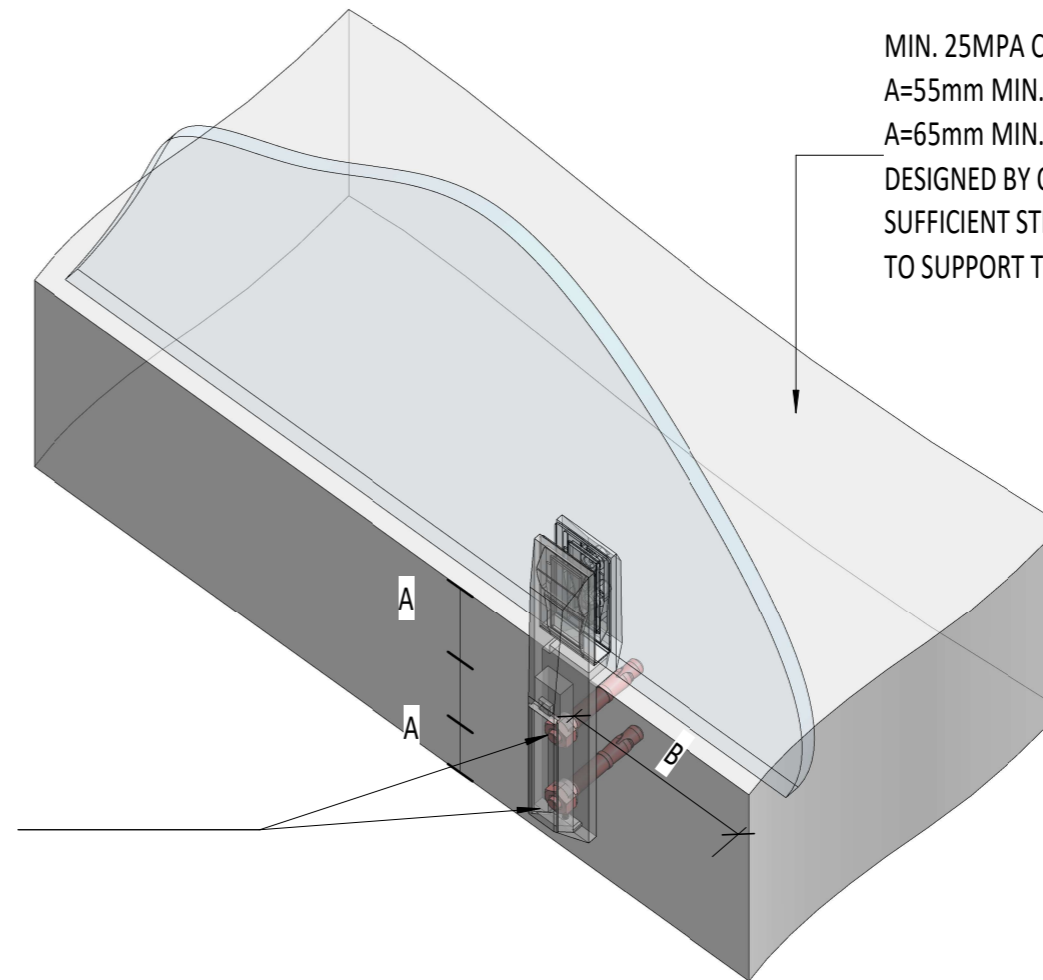

MIN. 25MPA CONCRETE
A=55mm MIN. 180mm THICK
A=65mm MIN. 200mm THICK
DESIGNED BY OTHERS TO HAVE SUFFICIENT STRENGTH AND RIGIDITY TO SUPPORT THE BALUSTRADE

CONNECTION TO CONCRETE

IMPORTANT INSTALLATION INSTRUCTIONS:

ALL PROPRIETARY PRODUCTS INCLUDING ANCHORS MUST BE INSTALLED IN STRICT ORDER WITH MANUFACTURER PROCEDURES.



7 Market Street
Napier. 4110

m. 0210398833, m.0211099712
www.extra-mile.co.nz, info@extra-mile.co.nz

Client:
STORETECH LIMITED

Project:
KAWEKA FIXING SPIGOT

Drawing:
BALUSTRADE CONNECTION
DETAILS SHEET 2

REF.	DESCRIPTION	DATE
R.2	CONCRETE FIXING REVISED	221202
R.3	WURTH ANCHORS AND GLASS NOTE ADDED. CONC. EDGE DIST. CHANGED.	230922
R.4	M12 ANCHORS REPLACED WITH M10 WHERE RELEVANT	230929
scale: @A3	drawn: AM	checked: PM
	status: P	project no: 20073
	drg no: KB05	rev: R.4

Section 3 – F2 Compliance

SAFETY GLASS CERTIFICATION F2: COMPLIANCE

STATEMENT OF COMPLIANCE

To satisfy the New Zealand Building Code Acceptable Solution F2/AS1, glass likely to come into contact with people must comply with NZS 4223: Part 3:2016 Code of practice for glazing in buildings – Human impact safety requirements.

NZS 4223: Part 3:2016 requires Grade A safety glass to be used in shower doors, shower screens and bath enclosures and Glass Pool Fencing.

Scenik Fencing confirms glass used in our Glass Pool Fencing and Balustrade has been produced to one or more of the following standards as outlined in NZS:4223:2016: Page Vi

AS/NZS 2208:1996 Grade A

NZS 8500:2006

BS 6206 Grade A

ANSI Z97.1

Peter Carney GENERAL MANAGER

M: 0800 235 2473 | Info@scenik.co.nz

Signed: *Peter Carney*

Scenik Fencing
To the attention of Peter Carney
Storetech Industries
Napier

16129 / Structural Assessment of 25x21 "Nanorail" Handrail for Glass Balustrades

To Whom It May Concern,

This is to certify that Storetech Industried Limited (t/a Scenik Fencing) engaged ExtraMile Consulting Structural Engineers to assess structural capacity of the "Nanorail" 25x21mm handrail (see appendix B) in the context of the New Zealand building Code.

The assessment was carried out in accordance with New Zealand and Australian Standards (NZS 4223.3:2016, all cited in Compliance Documents B1/VM1 and AS1).

The assessment was carried out by a Chartered Professional Engineer qualified and experienced in design of this type of sections.

It was established that the handrail meets the requirements of part B1/AS1 and B2 of the New Zealand Building Code for building occupancy types A, B and E (as defined in table 3.3 of AS/NZS1170.1:2002).

The handrail as shown below has been allowed for and included in this Ps1 Ref page 2.



Pawel Milewski
MEng(Hons) CPEng MIPENZ IntPE
For and on Behalf of ExtraMile Consulting Limited

Appendix B: HANDRAIL JOINS

All joints can be fixed using a stainless Steel 4.8mm x mm Countersunk Rivet. Grip Range (1/16') Units.

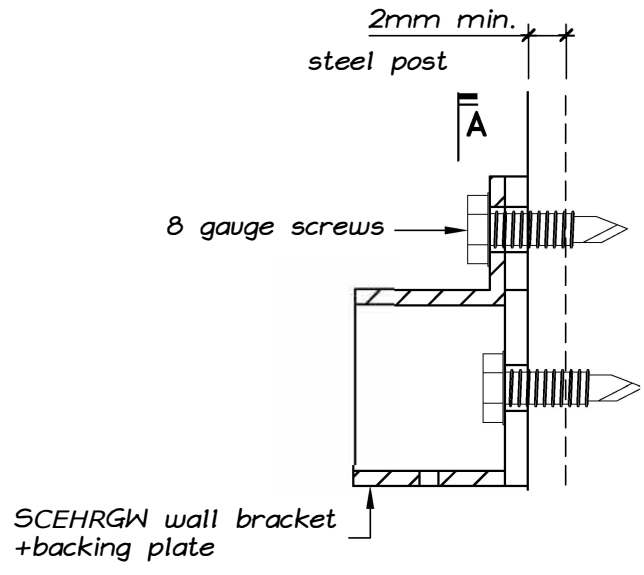

STEEL POST FIXING

1:1 elevation

Handrail to Wall or Handrail to Post:

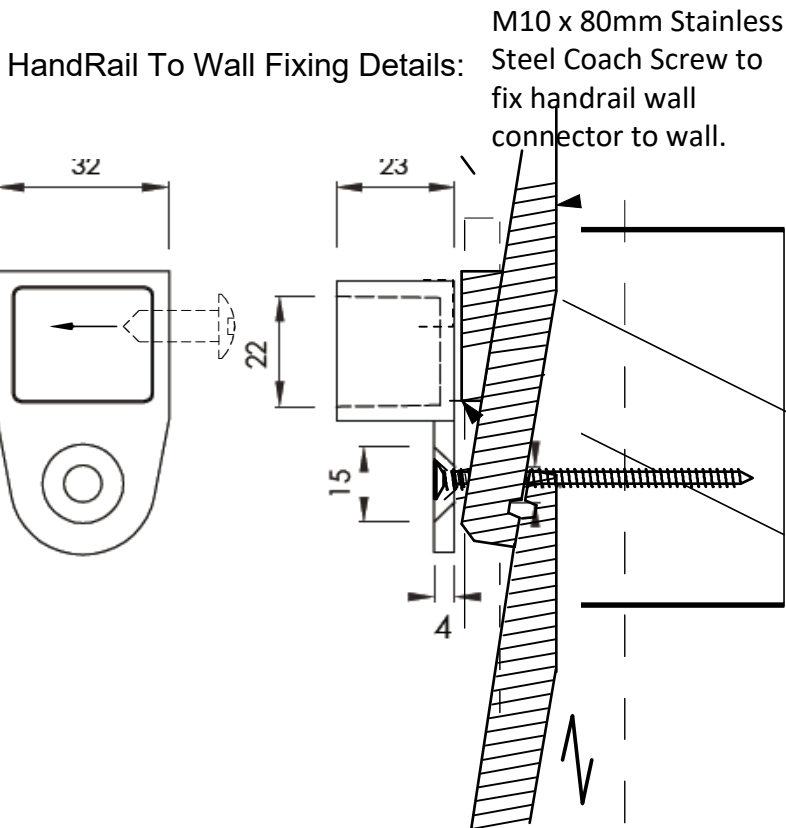

Masonry wall fixing for handrail bracket to wall.

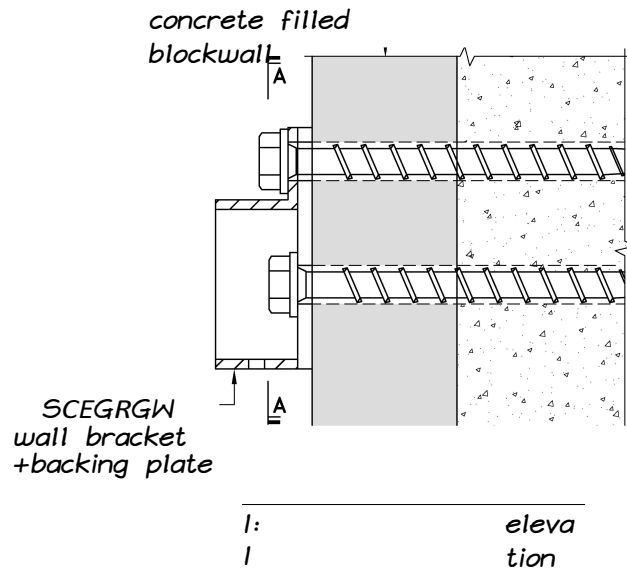

If Wall is a flat surface then mount with the above fixing directly onto the wall.

Please Note: Where this is an exterior house wall please use a good quality silicone applied to the hole prior to screwing.

HANDRAIL – 5800mm x 25mm x 21mm

316 Stainless Steel

SLIMLINE
RAIL



COMPLIANT WITH
NZS4223:2016

Order Code: SCEHR5.8 (polish finish)

SPECIFICATION

- Slimline stylish profile - caps over 12mm thick glass
- 1.2mm wall thickness
- 14 x14mm glazing pocket: silicone onto glass or use in conjunction with glazing rubber
- To be compliant with NZS4223:2016
 - approved Balustrade Handrail

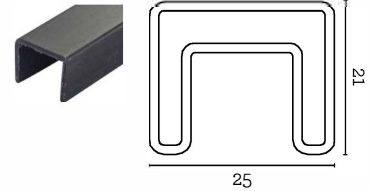

180° CONNECTOR – 25mm x 21mm

316 Stainless Steel



Order Code: SCEHR180 (polish finish)

SPECIFICATION

- In-line rail joiner
- Easy to use tap-in fitting: allows for increased speed of assembly
- Stainless Steel 316; High Polish finish
- Friction fitting or epoxy can be used

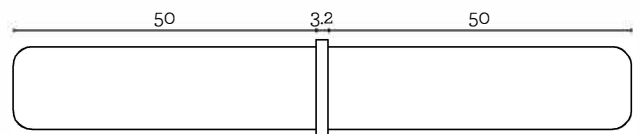

90° CONNECTOR – 25mm x 21mm

316 Stainless Steel



Code: SCEHR90 (polish finish)

SPECIFICATION

- 90 degree corner joiner ; easy to use tap-in fitting
- Stainless Steel 316; High Polish finish
- Epoxy glue, weld or drill/tap tube for joining strength

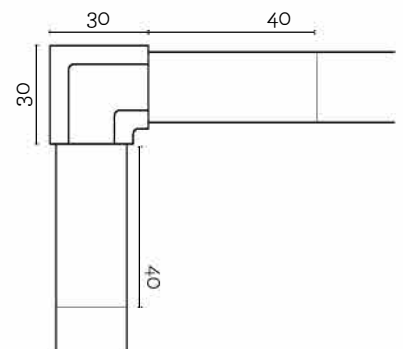

SWIVEL HORIZONTAL CONNECTOR

316 Stainless Steel



Order Code: SCEHRH

SPECIFICATION

- Variable angle horizontal joiner
- From straight rail, achieve up to 45 degrees left or right angle joining
- Epoxy glue, weld or drill/top tube for joining strength

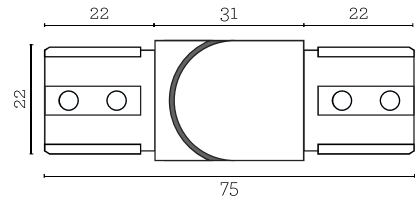

SWIVEL VERTICAL CONNECTOR

316 Stainless Steel



Order Code: SCEHRV

SPECIFICATION

- Variable angle vertical joiner
- From straight rail, achieve up to 45 degrees upwards & downwards
- Ideal for staircase installation

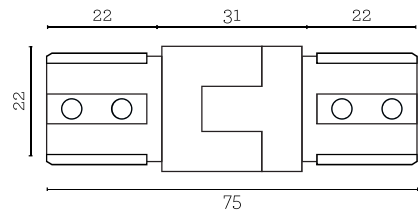

END CAP – 25mm x 21mm

316 Stainless Steel



Order Code: SCEHREC

SPECIFICATION

- End cap; easy to use tap-in fitting
- Stainless Steel 316; high polish finish
- Epoxy glue, weld or drill/tap tube for joining strength

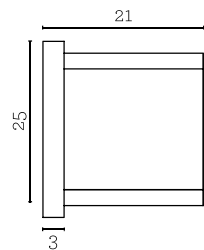

WALL PLATE – 25mm x 21mm

316 Stainless Steel



Order Code: SECHRWC

SPECIFICATION

- Bracket can be affixed to wall/post
- 25 x 21mm tube fits into opening (female fit)
- Stainless Steel 316; high polish finish
- Epoxy glue, weld or drill/tap tube for joining strength

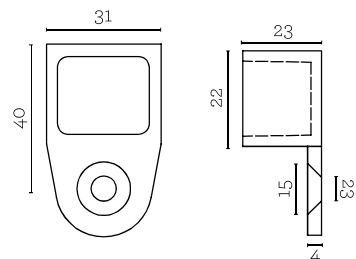

INTERLINKING HANDRAIL SYSTEM

INTERLINKING HANDRAIL

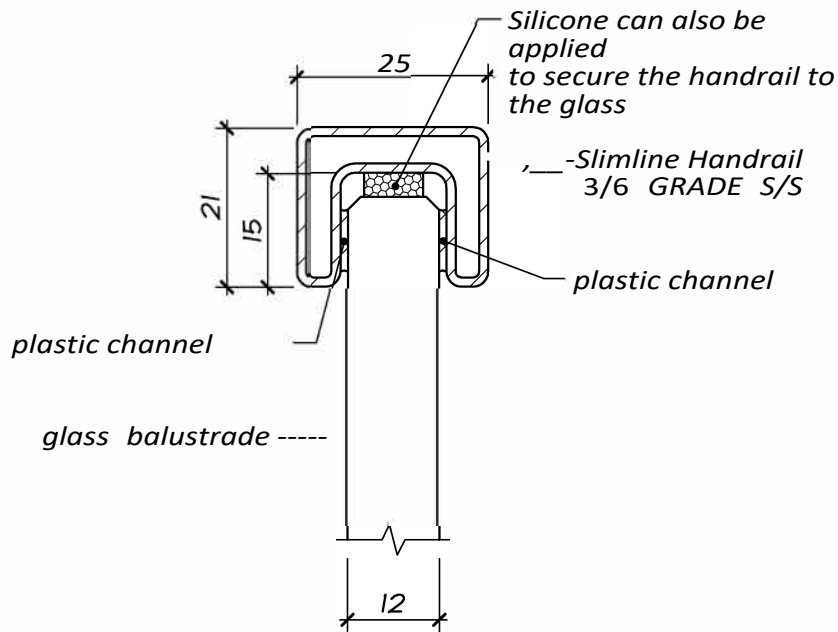

Channel or Silicone seal

1:1

NOTES:

·interlinking handrail details are only to be used on cantilevered glass balustrades

·'span' refers to the width of glass barrier panels. Span =glass panel width + gap between panels

·'3 span continuous' refers to a configuration where the interlinking handrail segment has at least 3 glass barrier panels in a straight line

·'1 span - simple support' refers to a configuration where the interlinking handrail segment has 1 or 2 glass barrier panels in a straight line

525-

·all screws are to be stainless steel and have a minimum ultimate shear strength of 3.5KN per screw

·interlinking handrails are applicable for occupancy loading type A -domestic and residential and type C3 - areas without obstacles for moving people as per NZS170.1 only

